

**Features**

- ❑ **backupower™ charger on-the-go from a single AA battery to mobile device**
- ❑ **Simultaneous charging of a mobile device and a rechargeable AA NiMH battery**
- ❑ **Instant-talk** - powers-up a mobile device, even if its battery is fully depleted
- ❑ **Foldable AC Power plug** for smooth and easy carrying
- ❑ USB output connector – 5v/500mA from AA battery or 5v/800mA when connected to AC
- ❑ High conversion efficiency - up-to 92%
- ❑ Outputs up-to 2Wh from a single AA battery
- ❑ Fully automatic operation
- ❑ Indicator LEDs to show AC power connected, AA battery charging and backupower™ active (when charging a mobile device from the AA battery)
- ❑ Safety features include short circuit protection, reverse polarity protection, maximum voltage, maximum temperature & maximum charging time

**Description**

The “Wally” is a 3-in-1 charger: a compact travel charger that can (1)charge electronic devices and (2)rechargeable NiMH AA battery, and is also (3)a backupower™ charger that can charge electronic devices using a AA battery as the power source.

The “Wally” can simultaneously recharge an electronic device and rechargeable AA battery when it’s plugged into an AC socket. The “Wally” is designed to optimally charge mobile phones.

The “Wally” is ideal for use as a travel charger, eliminating the need to carry a bulky device charger. It is also suitable for areas where AC power is not easily available. For everyday use, a NiMH battery can be inserted and charged through the “Wally” using any standard AC outlet.

The “Wally” uses a maximum voltage, timer, and temperature comparator to determine end-of-charge of the NiMH battery.

The “Wally” was developed using Techtium’s TEC110A as the main up-converter / charger. It was designed to maximize charging current and efficiency in order to deliver optimal charge to the battery. It starts up automatically when a device drawing current is connected at the output, enabling the immediate operation of the device even if its battery is fully depleted.

**Physical Illustration**

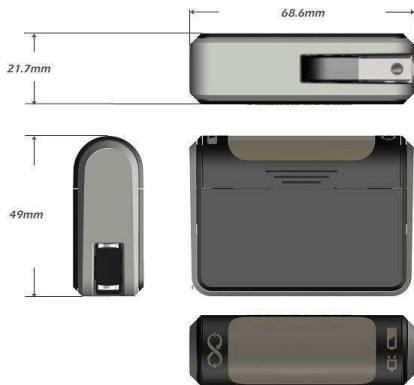

## **Absolute Maximum Ratings**

---

|   |       |
|---|-------|
| Maximum NiMH battery voltage ( $V_{ALK+} - V_{ALK-}$ )..... | 3.0 V |
| Maximum device voltage ( $V_{OUT+} - V_{OUT-}$ ) .....      | 5.3 V |
| Maximum AC side voltage ( $V_{IN+} - V_{IN-}$ ) .....       | 270 V |

## **Specifications**

---

| Parameter                           | Test Conditions                     | Limits           |     |     | Units             |
|-------------------------------------|-------------------------------------|------------------|-----|-----|-------------------|
|                                     |                                     | Min              | Typ | Max |                   |
| Device Side Voltage Range           | Device connected                    | 3                |     | 5.2 | V                 |
| AC Side Voltage Range               |                                     | 90               | -   | 265 | V                 |
| Open-Circuit Voltage                | $V_{low} = 1.5 V$                   | 5                | 5.1 | 5.2 | V                 |
| Switching Frequency                 | $V_{hi} < 4.5 V$                    | 225              | 250 | 275 | kHz               |
| End of Charge Current               |                                     | 10               | 15  | 25  | mA                |
| Standby current consumption from AA | $V_{low} = 1.5 V$<br>Any load       | 100              | 200 | 250 | $\mu A$           |
| Ripple at Device Side               | $V_{hi} = 5 V$<br>$V_{low} = 1.5 V$ |                  | 75  |     | mV <sub>p-p</sub> |
| Time to Shutdown                    | Open circuit                        |                  | 10  |     | sec               |
| NiMH Charge Current                 |                                     |                  | 350 |     | mA                |
| AA under-voltage lockout            |                                     |                  | 0.7 |     | V                 |
| Dimensions                          | AC plug folded                      | 68.6 x 49 x 21.7 |     |     | mm                |

## **Battery and Device Characterization**

---

### **AC Power Plug**

The “Wally” comes with a foldable AC power plug (US standard) which makes it even more compact and ideal for traveling.

The “Wally” support universal AC voltage range, thus by using standard AC plug converters, the “Wally” can be used worldwide.

### **AA Battery**

The “Wally” is intended for use with one standard NiMH AA battery.

### **Automatic Charging of AA Battery**

The “Wally” will automatically start charging a non-full AA battery when connected to an AC socket.

**Charging the AA Battery**

The “Wally” will charge a AA battery up-to 9 hours at a charging current rate of 350mA.

**End of Charge Detection of AA Battery**

The “Wally” monitors the AA battery voltage and detects the end of charge, through absolute voltage. In addition there is a maximum charging timeout of 9 hours and a maximum temperature to stop the charging.

**Device Side**

The “Wally” is designed to charge mobile phones and other similar devices that are powered by a one-cell Li-Ion battery of any capacity.

**Device Side Connector**

The device is connected to “Wally” via its USB connector.

Since each device model has different charging characteristics, it is possible that the charger will function differently with some models.

**Automatic Charging of Device Battery**

When a device is connected to the “Wally”, it will automatically start charging the device.

A AA battery that has previously been depleted will prevent the “Wally” from charging the device unless it has been recharged or replaced by a “fresh” battery.

**End of Charge Detection of Device Battery**

When charging a device’s battery the “Wally” monitors the voltage at the output if VOUT has reached 5V then the “Wally” will start charging in constant voltage mode decreasing the current to maintain the constant current when necessary. When the current has been reduced to less than 15 mA the “Wally” will end the charging of the device and will enter standby.

**Automatic Shutdown of “Wally”**

“Wally” will automatically shut down once the AA battery is depleted.

**Automatic standby of “Wally”**

The “Wally” will enter standby mode when:

- No device attached is attached to it
- The device battery and the AA battery are fully charged

## **“Wally” - backupower™ Mobile Wall Charger**

---

### **AC Connection**

#### **Power USB Connection**

When the “Wally” is connected to an AC socket, the user can charge a device via the USB connector and simultaneously charge the AA battery in the cavity.

#### **Safety**

The “Wally” has a short circuit protection at its USB output connector.

The “Wally” is intended for use with rechargeable NiMH AA battery or pre-charged rechargeable NiMH AA battery and must have similar label like ALL NiMH wall chargers have:

**“Recharge only rechargeable NiMH battery”.**

The “Wally” cavity has a mechanical reverse polarity protection. For proper operation, insert the AA battery according the polarity indication inside the cavity.

The “Wally” will stop charging the AA battery when:

- its voltage is too high or
- its temperature rises over 53°C or
- if charging timeout of 9 hours occur

The “Wally” will provide the best performance and highest safety when using a high quality AA battery from branded batteries manufacturers.

The “Wally” can use primary batteries as backupower source when not connected to an AC socket.

The “Wally” must NOT be inserted to an AC socket when a primary battery is inside.

If the user has inserted the “Wally” to an AC socket when a primary battery is inside, in most cases nothing will happen – but in some rare cases when the primary battery is low quality / damaged, there is a risk of fire or explosion like in all NiMH battery chargers.

## Operating Instructions

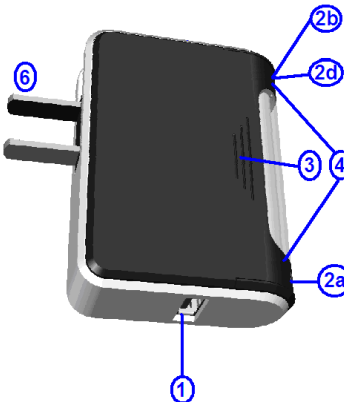
|  |   |
|--|---|
| <p><b>Charging a rechargeable AA battery inside (from an AC socket):</b></p> <ol style="list-style-type: none"> <li>1. Press the press-in area (Fig. A-3), pull-off the battery cavity lid (Fig. A-4) and insert a rechargeable NiMH AA battery inside the cavity</li> <li>2. Close the battery cavity lid (Fig. A-4)</li> <li>3. Plug-in the “Wally” to an AC socket using its swivel AC plug (Fig. A-6)</li> <li>4. The power-in indication LED (Fig. A-2b) will light in red</li> <li>5. The AA charging LED (Fig. A-2d) will start flashing in orange*</li> <li>6. When the AA battery is fully charged, the LED (Fig. A-2d) will turn-off**</li> </ol> <p>Now your “Wally” has available portable-power in it.</p> <p>* Note: Only non-full AA batteries will start charging<br/>                 ** Note: it can take up-to 9 hours to fully charge the rechargeable NiMH AA battery</p> |  <p align="center"><b>Fig. A</b></p>  |
| <p><b>Charging a portable device (from the AA battery):</b></p> <ol style="list-style-type: none"> <li>1. Select the correct tip to fit the portable device you would like to charge</li> <li>2. Connect the selected tip to the USB power output connector (Fig. A-1) of the “Wally”</li> <li>3. Connect the other side of the tip to the device you would like to charge</li> <li>4. The “Wally” will automatically start. The LED (Fig. A-2a) will flash in yellow</li> <li>5. When the device under charge is fully charged or it is disconnected, the “Wally” will automatically stop and preserve energy left in the AA battery for future use.</li> </ol> <p>Note: if the AA battery inside is empty, you can always replace it with a fresh AA. When you insert a fresh AA, the yellow LED will flash briefly</p>  | <p><b>Charging a Device and a AA battery simultaneously:</b></p> <ol style="list-style-type: none"> <li>1. Connect to an AC socket as described in “Charging a AA battery inside (from an AC socket)”</li> <li>2. Connect the device as described in “Charging a Device (from a AA battery)”</li> <li>3. The “Wally” will simultaneously charge both the device and AA inside it</li> </ol> |

## LED Indications

The “Wally” includes LEDs that indicate its current operation. The indications are as follows:

- Yellow LED blinking: Backupower™ is active
- Orange LED blinking: AA battery is being charged
- Red LED: An external power source is connected

## Typical Performance Characteristics

Discharge Current Vs. Vout

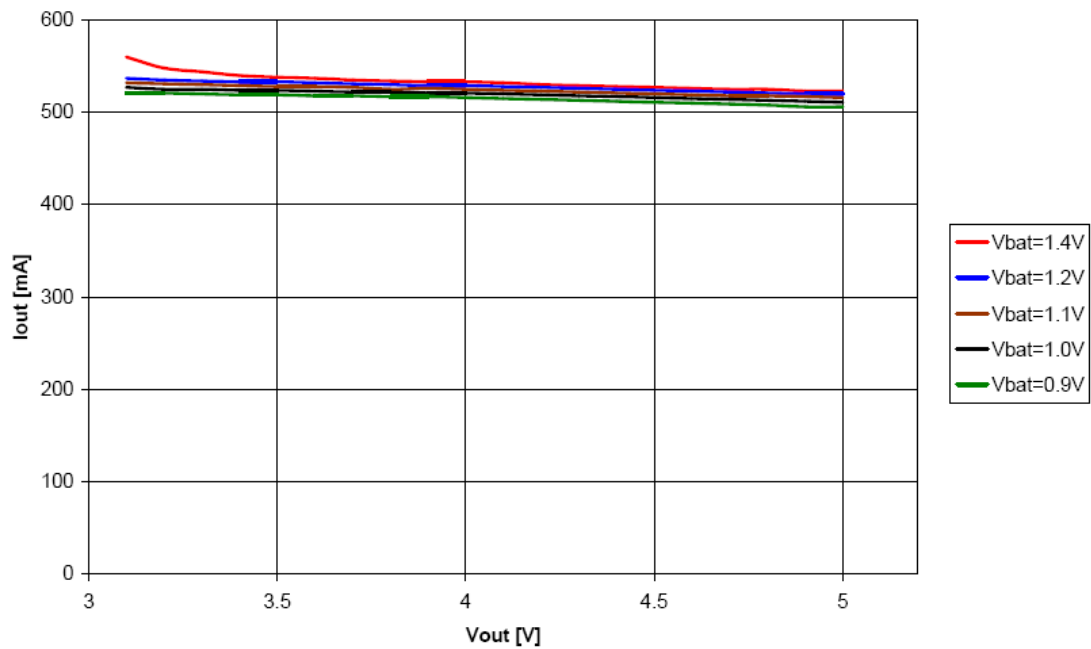

Discharge Efficiency Vs. Vout

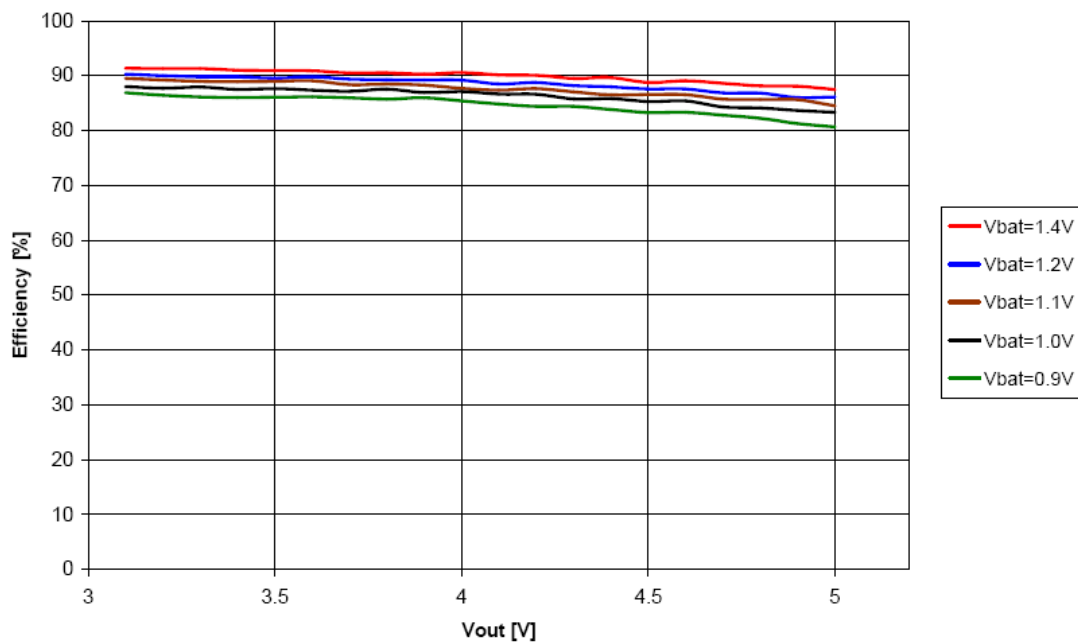

**Test Circuit :**

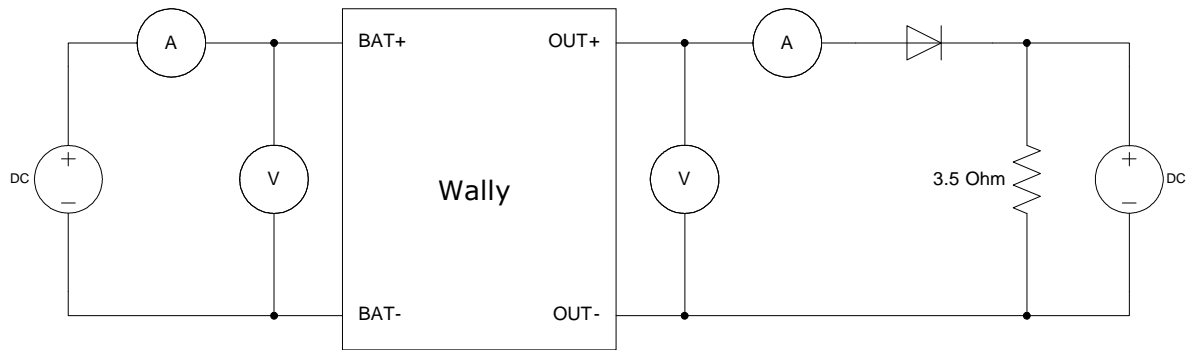

# Electrical Circuit Schematic

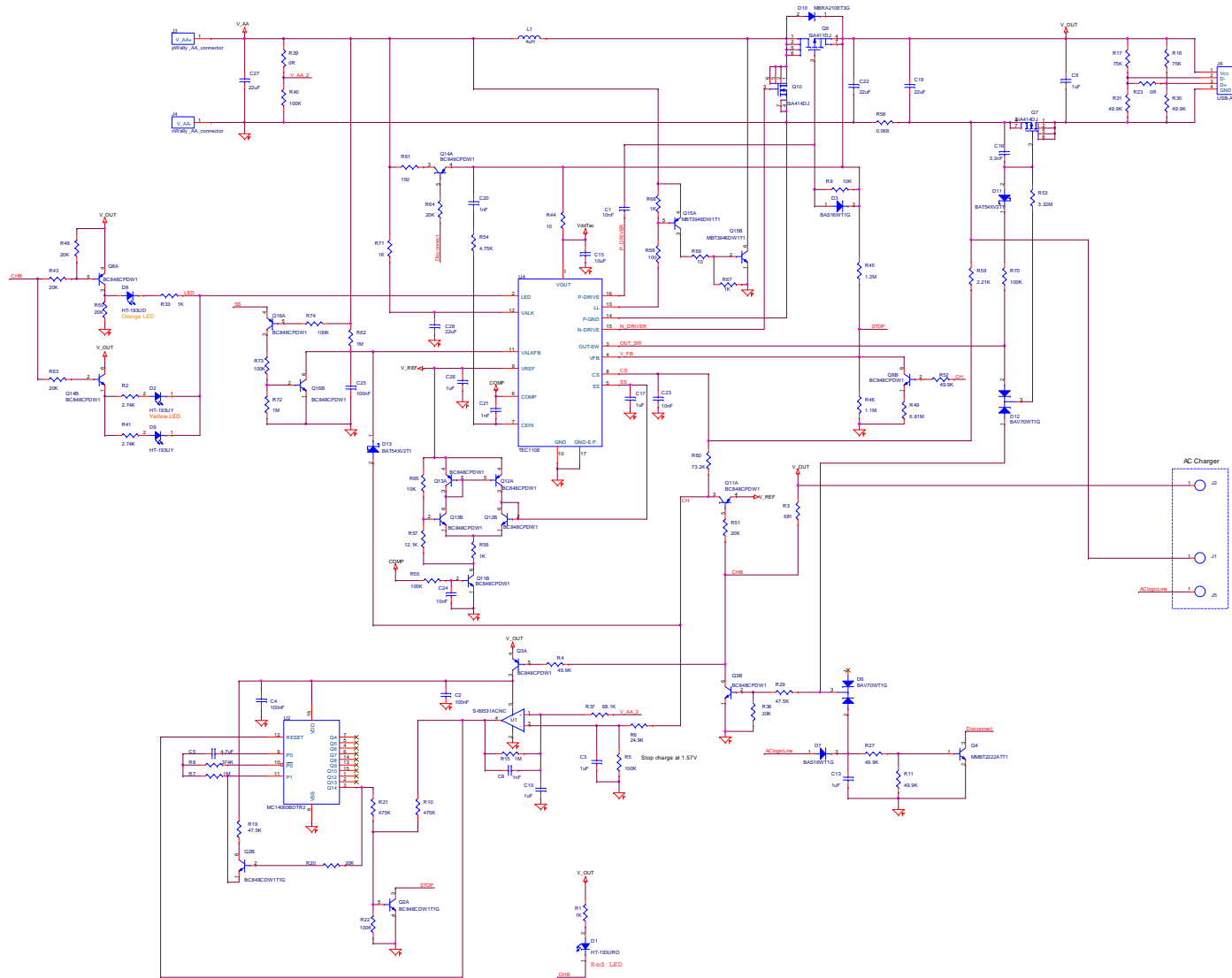

## Electrical Component List

Orcad version WA1-SIL1-E-01p

| Reference                 | Qty | Package           | Description                                | Part Number     | Manufacturer |
|---------------------------|-----|-------------------|--|-----------------|--------------|
| <b>Ceramic Capacitors</b> |     |                   |  |                 |              |
| C1,C23,C24                | 3   | 0402              | Capacitor 10nF 10V X5R 20%                 | LMK105BJ103MV-T | Taiyo-Yuden  |
| C2,C4,C25                 | 3   | 0402              | Capacitor 100nF 10V X5R 20%                | LMK105BJ104MV-T | Taiyo-Yuden  |
| C3,C9,C10,C13,C17,C26     | 6   | 0402              | Capacitor 1uF 10V X5R 20%                  | LMK105BJ105MV-F | Taiyo-Yuden  |
| C5                        | 1   | 0603              | Capacitor 4.7uF 10V X5R 10%                | LMK107BJ475KA-T | Taiyo-Yuden  |
| C8,C20,C21                | 3   | 0402              | Capacitor 1nF 10V X5R 20%                  | LMK042BJ102MC-F | Taiyo-Yuden  |
| C15                       | 1   | 0805              | Capacitor 10uF 16V X5R 20%                 | EMK212BJ106MG-T | Taiyo-Yuden  |
| C16                       | 1   | 0402              | Capacitor 3.3nF 10V X5R 20%                | JMK042BJ332MC-F | Taiyo-Yuden  |
| C19,C22,C27               | 3   | 0805              | Capacitor 22uF 10v X5R 20%                 | LMK212BJ226MG-T | Taiyo-Yuden  |
| C28                       | 1   | 0603              | Capacitor 22uF 4v X5R 20%                  | AMK107BJ226MA-T | Taiyo-Yuden  |
| <b>Diodes</b>             |     |                   |  |                 |              |
| D1                        | 1   | LED_0603          | SMD Red LED 0603                           | HT-193URO       | Harvatek     |
| D2,D9                     | 2   | LED_0603          | SMD Yellow LED 0603                        | HT-193UY        | Harvatek     |
| D3,D7                     | 2   | SC70-3            | Small Signal Diode                         | BAS16WT1G       | On           |
| D6,D12                    | 2   | SC70-3            | Dual Small Signal Diode - Common Cathode   | BAV70WT1G       | On           |
| D8                        | 1   | LED_0603          | SMD Orange LED                             | HT-193UD        | Harvatek     |
| D10                       | 1   | SMA               | Schottky Power Rectifier                   | MBRA210ET3G     | On           |
| D11,D13                   | 2   | SOD523            | Small Signal Schottky Diode                | BAT54XV2T1      | On           |
| <b>Inductors</b>          |     |                   |  |                 |              |
| L1                        | 1   | 7.8x7.0x4.8       | INDUCTOR 4 $\mu$ H +/-0.7 $\mu$ H, 14 mOhm | HM-DRO7050001   | HiMax        |
| <b>Transistors</b>        |     |                   |  |                 |              |
| Q2                        | 1   | SC70-6            | Dual NPN Transistors                       | BC848CDW1T1G    | On           |
| Q3,Q8,Q11,Q12,Q13,Q14,Q16 | 7   | SC70-6            | Dual Transistors NPN/PNP                   | BC848CPDW1      | On           |
| Q4                        | 1   | SC-75             | General Purpose NPN Transistor             | MMBT2222ATT1    | ON           |
| Q7,Q10                    | 2   | POWERPAK-SC70-6_S | N-Channel 8-V (D-S) MOSFET                 | SiA414DJ-T1-GE3 | Vishay       |
| Q9                        | 1   | POWERPAK-SC70-6_S | P Channel MOSFET                           | SiA411DJ-T1-GE3 | Vishay       |
| Q15                       | 1   | SC70-6            | Dual Transistors NPN/PNP                   | MBT3946DW1T1    | On           |

## “Wally” - backupower™ Mobile Wall Charger

|  |   |                            |                          |                         |                      |
|--|---|----------------------------|--------------------------|-------------------------|----------------------|
| <b>Resistors</b>                         |   |                            |                          |                         |                      |
| R1,R33,R56,R66,<br>R67,R71               | 6 | 0402                       | Resistor 1K Ohm 1%       |                         |                      |
| R2,R41                                   | 2 | 0402                       | Resistor 2.74K Ohm 1%    |                         |                      |
| R3                                       | 1 | 0402                       | Resistor 681 Ohm 1%      |                         |                      |
| R4,R11,R27,R30,<br>R31,R52               | 6 | 0402                       | Resistor 49.9K Ohm 1%    |                         |                      |
| R5,R22,R40,R55,<br>R70,R73,R74           | 7 | 0402                       | Resistor 100K Ohm 1%     |                         |                      |
| R6                                       | 1 | 0402                       | Resistor 24.9K Ohm 1%    |                         |                      |
| R7,R15,R62,R72                           | 4 | 0402                       | Resistor 1M Ohm 1%       |                         |                      |
| R8                                       | 1 | 0402                       | Resistor 374K Ohm 1%     |                         |                      |
| R9,R65                                   | 2 | 0402                       | Resistor 10K Ohm 1%      |                         |                      |
| R10,R21                                  | 2 | 0402                       | Resistor 475K Ohm 1%     |                         |                      |
| R16,R17                                  | 2 | 0402                       | Resistor 75K Ohm 1%      |                         |                      |
| R19,R29                                  | 2 | 0402                       | Resistor 47.5K Ohm 1%    |                         |                      |
| R20,R36,R43,<br>R48,R50,R51,<br>R63, R64 | 8 | 0402                       | Resistor 20K Ohm 1%      |                         |                      |
| R23,R39                                  | 2 | 0402                       | Resistor 0 Ohm           |                         |                      |
| R37                                      | 1 | 0402                       | Resistor 68.1k Ohm 1%    |                         |                      |
| R44,R69                                  | 2 | 0402                       | Resistor 10 Ohm 1%       |                         |                      |
| R45                                      | 1 | 0402                       | Resistor 1.2M Ohm 1%     |                         |                      |
| R46                                      | 1 | 0402                       | Resistor 1.1M Ohm 1%     |                         |                      |
| R49                                      | 1 | 0402                       | Resistor 6.81M Ohm 1%    |                         |                      |
| R53                                      | 1 | 0402                       | Resistor 3.32M Ohm 1%    |                         |                      |
| R54                                      | 1 | 0402                       | Resistor 4.75K Ohm 1%    |                         |                      |
| R57                                      | 1 | 0402                       | Resistor 12.1K Ohm 1%    |                         |                      |
| R58                                      | 1 | 0805                       | Resistor 0.075 1%        | WSL0805 0.075 1%<br>RT1 | Vishay               |
| R59                                      | 1 | 0402                       | Resistor 2.21K Ohm 1%    |                         |                      |
| R60                                      | 1 | 0402                       | Resistor 73.2K Ohm 1%    |                         |                      |
| R61                                      | 1 | 0402                       | Resistor 150 Ohm 1%      |                         |                      |
| R68                                      | 1 | 0402                       | Resistor 100 Ohm 1%      |                         |                      |
| <b>Integrated Circuits</b>               |   |                            |                          |                         |                      |
| U1                                       | 1 | SC88-5                     | RtoR Comparator          | S-89531ACNC-<br>HCCTFG  | Seiko<br>Instruments |
| U2                                       | 1 | TSSOP-16                   | 14-stage binary counters | MC14060BDTR2            | On                   |
| U4                                       | 1 | QFN-<br>16_4x4mm           | Charge Controller        | TEC110ARSAG             | Techtium             |
| <b>Contacts/<br/>Connectors</b>          |   |                            |                          |                         |                      |
| J1,J2,J5                                 | 3 | 1mmX0.5mm                  | TrueAll connection       |                         |                      |
| J3                                       | 1 | pWally_AA_co<br>nconnector | Wally AA connector +     |                         |                      |
| J4                                       | 1 | nWally_AA_co<br>nconnector | Wally AA connector -     |                         |                      |
| J6                                       | 1 | USB_A_F_TH_<br>PS          | USB-A T.H. connector     | A0-062-08079            | FM                   |
| <b>Printed Circuit<br/>Board</b>         |   |                            |                          |                         |                      |
|  | 1 |                            | PCB                      | WS1-SIL1-E-0            | Techtium             |

**Notes**

---

1. The “Wally” can be also provided as a module – for more details please contact Techtium sales.

**PROPRIETARY INFORMATION NOTICE**

THIS DATASHEET INCLUDING THE INFORMATION AND DATA CONTAINED HEREIN OR DELIVERED PURSUANT HERETO (COLLECTIVELY, THE “PROPRIETARY INFORMATION”) IS THE PROPERTY OF TECHTIUM LTD. (THE “COMPANY”) AND IS CONSIDERED TO BE STRICTLY CONFIDENTIAL. THE RECIPIENT (I) SHALL NOT DISSEMINATE, REPRODUCE, UTILIZE OR DISCLOSE THE PROPRIETARY INFORMATION OTHER THAN FOR INTERNAL BONA FIDE USE WITHIN THE RECIPIENT’S ORGANIZATION, AND (II) SHALL NOT INFRINGE THE COMPANY’S PROPRIETARY RIGHTS IN CONNECTION WITH THE PROPRIETARY INFORMATION.

**NOTE:** IF YOU DO NOT AGREE TO THE TERMS OF THIS PROPRIETARY INFORMATION NOTICE, PLEASE REFRAIN FROM USING ANY ELEMENT OF PROPRIETARY INFORMATION IN ANY MANNER WHATSOEVER AND IMMEDIATELY DESTROY ANY AND ALL COPIES OF THIS DATASHEET, FAILING WHICH YOU SHALL BE DEEMED ACCEPTING AND CONSENTING TO SUCH TERMS.

***Techtium Ltd.*** – [www.Techtium.com](http://www.Techtium.com) – [info@techtium.com](mailto:info@techtium.com)

Tel: +972-3-644-3747 – US Toll Free: 1-866-798-7671 – Fax: +972-3-644-3742

Techtium Ltd. assumes no responsibility for use of any information or external circuitry described. No circuit patent licenses are implied. Techtium reserves the right to change circuitry and specifications without notice at any time.